

8", Steel Frame
 1.4" 1-PISV2W Voice Coil, GFB-P Former
 Paper Cone, Foam Surround
 Dual Ferrite Magnet Motor System
 High Sensitivity

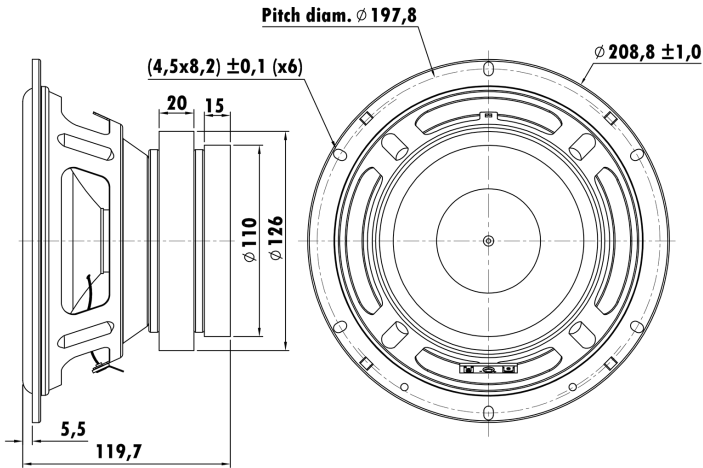

T-S Parameters

Resonance frequency [fs]	63.8 Hz
Mechanical Q factor [Qms]	19.531
Electrical Q factor [Qes]	0.615
Total Q factor [Qts]	0.597
Force factor [Bl]	7.778 Tm
Mechanical resistance [Rms]	0.643 kg/s
Moving mass [Mms]	30.884 g
Compliance [Cms]	0.201 mm/N
Effective diaph. diameter [D]	160.3 mm
Effective piston area [Sd]	206.12 cm ²
Equivalent volume [Vas]	12.0966 l
Sensitivity (2.83V/1m)	94 dB
Ratio Bl/√Re	4.491 N/√W
Ratio fs/Qts	106.867 Hz

Electrical Data

Nominal impedance [Zn]	3 Ω
Minimum impedance [Zmin]	3.388 Ω
Maximum impedance [Zo]	48.845 Ω
DC resistance [Re]	3 Ω
Voice coil inductance [Le]	0.414 mH

Power Handling

100h RMS noise test (IEC 17.1)	50 W
Long-term max power (IEC 17.3)	- W

Voice Coil & Magnet Data

Voice coil diameter	35.5 mm
Voice coil height	14.8 mm
Voice coil layers	2
Height of gap	6 mm
Linear excursion	± 4.4 mm
Max mech. excursion	\pm - mm
Unit weight	2.62 kg

