

8", Steel Frame  
 1.4" 1-PISV2W Voice Coil, GFB-P Former  
 Paper Cone, FOAM Surround  
 Ferrite Magnet Motor System  
 High Sensitivity

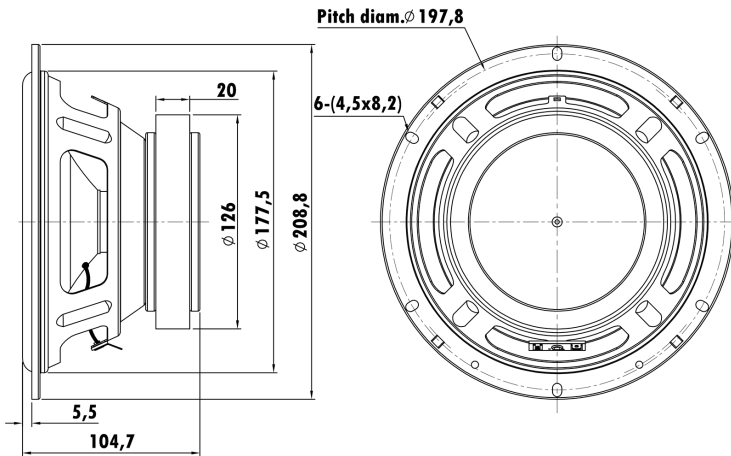

### T-S Parameters

Resonance frequency [fs]	63.8 Hz
Mechanical Q factor [Qms]	17.928
Electrical Q factor [Qes]	0.695
Total Q factor [Qts]	0.669
Force factor [Bl]	7.638 Tm
Mechanical resistance [Rms]	0.702 kg/s
Moving mass [Mms]	31.4 g
Compliance [Cms]	0.198 mm/N
Effective diaph. diameter [D]	160.3 mm
Effective piston area [Sd]	206.12 cm <sup>2</sup>
Equivalent volume [Vas]	11.9218 l
Sensitivity (2.83V/1m)	94 dB
Ratio Bl/√Re	4.256 N/√W
Ratio fs/Qts	95.37 Hz

### Electrical Data

Nominal impedance [Zn]	4 Ω
Minimum impedance [Zmin]	3.625 Ω
Maximum impedance [Zo]	51.5 Ω
DC resistance [Re]	3.22 Ω
Voice coil inductance [Le]	0.443 mH

### Power Handling

100h RMS noise test (IEC 17.1)	50 W
Long-term max power (IEC 17.3)	- W

### Voice Coil & Magnet Data

Voice coil diameter	35.5 mm
Voice coil height	14.5 mm
Voice coil layers	2
Height of gap	6 mm
Linear excursion	± 4.25 mm
Max mech. excursion	± - mm
Unit weight	2.170 kg

