

2.3", Steel Frame
 0.7"PESVW Voice Coil, Kapton Former
 Paper Cone,IIR Surround
 Dual Ferrite Magnet Motor System

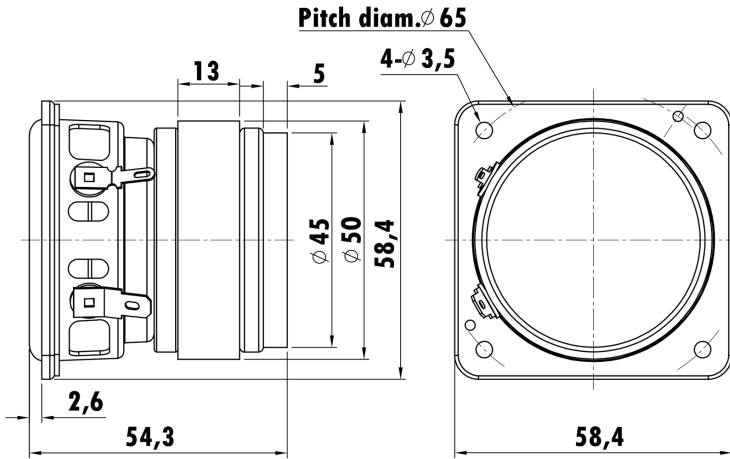

T-S Parameters

Resonance frequency [fs]	172.5 Hz
Mechanical Q factor [Qms]	7.245
Electrical Q factor [Qes]	1.497
Total Q factor [Qts]	1.241
Force factor [Bl]	2.068 Tm
Mechanical resistance [Rms]	0.416 kg/s
Moving mass [Mms]	2.783 g
Compliance [Cms]	0.306 mm/N
Effective diaph. diameter [D]	44.1 mm
Effective piston area [Sd]	15.27 cm ²
Equivalent volume [Vas]	0.1009 l
Sensitivity (2.83V/1m)	82 dB
Ratio Bl/√Re	1.126 N/√W
Ratio fs/Qts	139.0 Hz

Electrical Data

Nominal impedance [Zn]	4 Ω
Minimum impedance [Zmin]	3.68 Ω
Maximum impedance [Zo]	17.018 Ω
DC resistance [Re]	3.37 Ω
Voice coil inductance [Le]	0.223 mH

Power Handling

100h RMS noise test (IEC 17.1)	5 W
Long-term max power (IEC 17.3)	- W

Voice Coil & Magnet Data

Voice coil diameter	18.4 mm
Voice coil height	9 mm
Voice coil layers	2
Height of gap	5 mm
Linear excursion	± 2 mm
Max mech. excursion	$\pm -$ mm
Unit weight	0.31 kg

