

6.5", Steel Frame
1.2" PESVW Voice Coil, Aluminum Former
Paper Cone, Rubber Surround
Dual Ferrite Magnet Motor System
High Sensitivity

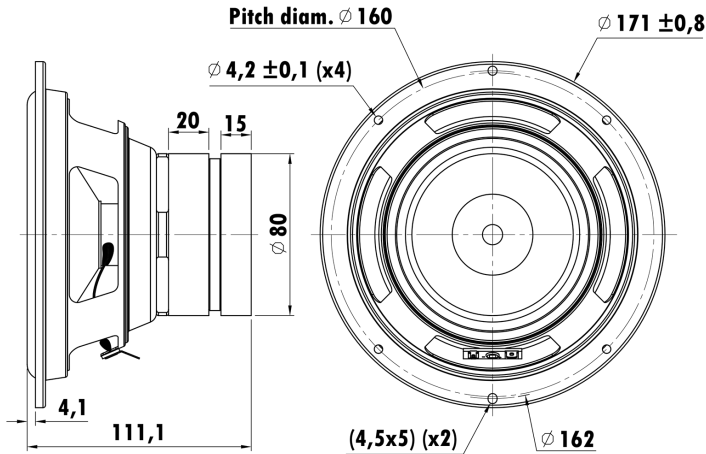

T-S Parameters

Resonance frequency [fs]	59.6 Hz
Mechanical Q factor [Qms]	6.3
Electrical Q factor [Qes]	0.95
Total Q factor [Qts]	0.83
Force factor [Bl]	6.9 Tm
Mechanical resistance [Rms]	2 kg/s
Moving mass [Mms]	34.3 g
Compliance [Cms]	0.2 mm/N
Effective diaph. diameter [D]	130 mm
Effective piston area [Sd]	132.7 cm ²
Equivalent volume [Vas]	5.1 l
Sensitivity (2.83V/1m)	87 dB
Ratio Bl/ \sqrt{Re}	3.74 N/ \sqrt{W}
Ratio fs/Qts	71.8 Hz

Electrical Data

Nominal impedance [Zn]	4 Ω
Minimum impedance [Zmin]	3.9 Ω
Maximum impedance [Zo]	24.6 Ω
DC resistance [Re]	3.4 Ω
Voice coil inductance [Le]	0.91 mH

Power Handling

100h RMS noise test (IEC 18.4)	60 W
Long-term max power (IEC 18.2)	100 W

Voice Coil & Magnet Data

Voice coil diameter	30.5 mm
Voice coil height	13.5 mm
Voice coil layers	4
Height of gap	6 mm
Linear excursion	± 3.75 mm
Max mech. excursion	\pm - mm
Unit weight	1.35 kg

