

8", Steel Frame
 1.4" 1-PISV2W Voice Coil, GFB-P Former
 Paper Cone, Rubber Surround
 Dual Ferrite Magnet Motor System
 High Sensitivity

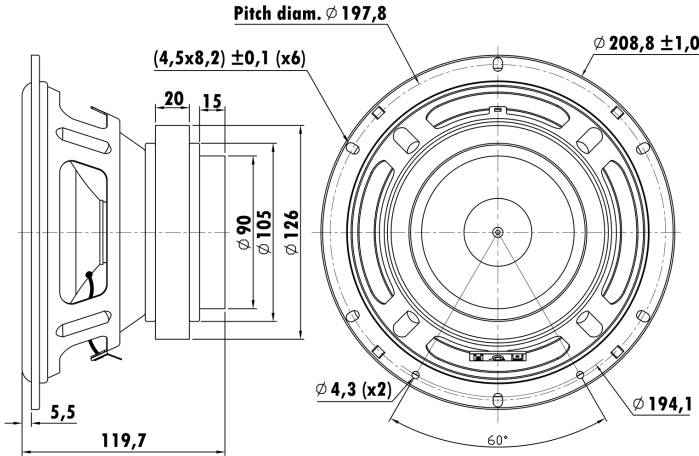

T-S Parameters

Resonance frequency [fs]	60.8 Hz
Mechanical Q factor [Qms]	6.526
Electrical Q factor [Qes]	0.518
Total Q factor [Qts]	0.480
Force factor [Bl]	9.976 Tm
Mechanical resistance [Rms]	2.375 kg/s
Moving mass [Mms]	40.578 g
Compliance [Cms]	0.169 mm/N
Effective diaph. diameter [D]	161 mm
Effective piston area [Sd]	203.58 cm ²
Equivalent volume [Vas]	9.9055 l
Sensitivity (2.83V/1m)	90 dB
Ratio Bl/√Re	5.48 N/√W
Ratio fs/Qts	127 Hz

Electrical Data

Nominal impedance [Zn]	4 Ω
Minimum impedance [Zmin]	4.37 Ω
Maximum impedance [Zo]	42.42 Ω
DC resistance [Re]	3.32 Ω
Voice coil inductance [Le]	1.023 mH

Power Handling

100h RMS noise test (IEC 18.4)	50 W
Long-term max power (IEC 18.2)	- W

Voice Coil & Magnet Data

Voice coil diameter	35.5 mm
Voice coil height	14.3 mm
Voice coil layers	4
Height of gap	6 mm
Linear excursion	± 4.15 mm
Max mech. excursion	± - mm
Unit weight	2.3 kg

