

2.25", Steel Frame
0.6" PESVW Voice Coil, Kapton Former
PP Cone, Rubber Surround
Ferrite Magnet Motor System
Frame Under Spider Vent, Low Distortion(<3%)

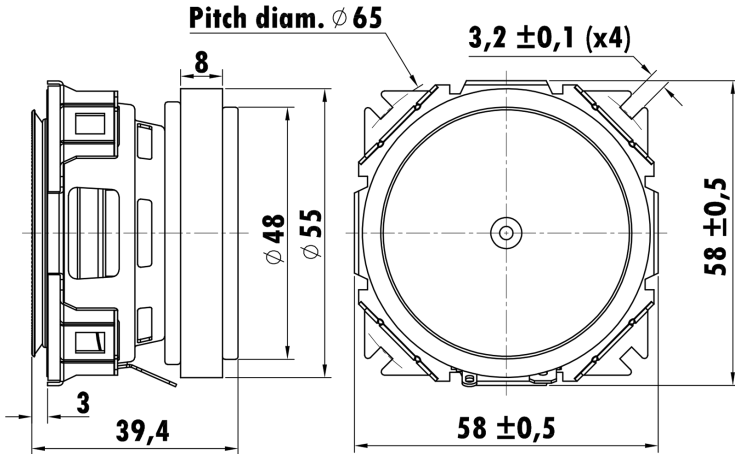

T-S Parameters

Resonance frequency [fs]	211 Hz
Mechanical Q factor [Qms]	4.717
Electrical Q factor [Qes]	2.18
Total Q factor [Qts]	1.491
Force factor [Bl]	3.768 Tm
Mechanical resistance [Rms]	0.916 kg/s
Moving mass [Mms]	3.255 g
Compliance [Cms]	0.174 mm/N
Effective diaph. diameter [D]	49 mm
Effective piston area [Sd]	18.85 cm ²
Equivalent volume [Vas]	0.0878 l
Sensitivity (2.83V/1m)	78 dB
Ratio Bl/ \sqrt{Re}	1.41 N/ \sqrt{W}
Ratio fs/Qts	141.52 Hz

Electrical Data

Nominal impedance [Zn]	8 Ω
Minimum impedance [Zmin]	7.9 Ω
Maximum impedance [Zo]	23 Ω
DC resistance [Re]	7.16 Ω
Voice coil inductance [Le]	0.421 mH

Power Handling

100h RMS noise test (IEC 17.1)	7 W
Long-term max power (IEC 17.3)	- W

Voice Coil & Magnet Data

Voice coil diameter	16.28 mm
Voice coil height	6.5 mm
Voice coil layers	2
Height of gap	3 mm
Linear excursion	± 1.75 mm
Max mech. excursion	\pm - mm
Unit weight	0.199 kg

