

2.5", Steel Frame
0.6" Voice Coil, Kapton Former, PESVW
Paper Cone, Rubber Coated Cloth Surround
Ferrite Magnet Motor
Paper Dome Center Cap
Basket Vent, Low Distortion

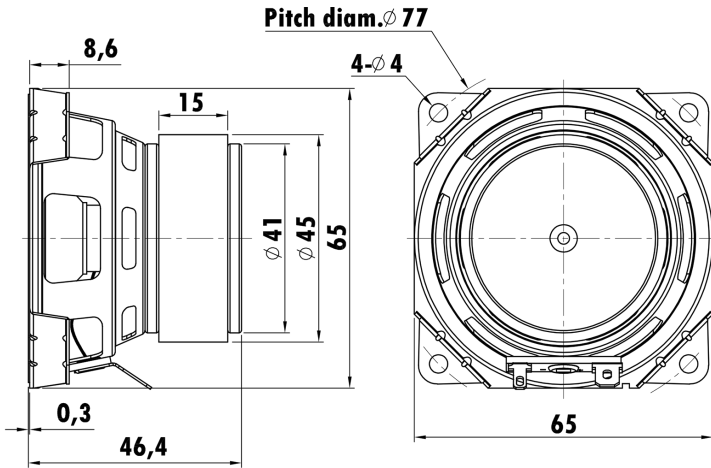

T-S Parameters

Resonance frequency [fs]	204 Hz
Mechanical Q factor [Qms]	5.67
Electrical Q factor [Qes]	1.48
Total Q factor [Qts]	1.17
Force factor [Bl]	2.33 Tm
Mechanical resistance [Rms]	0.41 kg/s
Moving mass [Mms]	1.84 g
Compliance [Cms]	0.32 mm/N
Effective diaph. diameter [D]	53 mm
Effective piston area [Sd]	22 cm ²
Equivalent volume [Vas]	0.22 l
Sensitivity (2.83V/1m)	85 dB
Ratio Bl/√Re	1.27 N/√W
Ratio fs/Qts	174 Hz

Electrical Data

Nominal impedance [Zn]	4 Ω
Minimum impedance [Zmin]	3.7 Ω
Maximum impedance [Zo]	13 Ω
DC resistance [Re]	3.4 Ω
Voice coil inductance [Le]	0.141 mH

Power Handling

100h RMS noise test (IEC 17.1)	36 W
Long-term max power (IEC 17.3)	- W

Voice Coil & Magnet Data

Voice coil diameter	14.28 mm
Voice coil height	6.8 mm
Voice coil layers	2
Height of gap	3 mm
Linear excursion	± 1.9 mm
Max mech. excursion	± - mm
Unit weight	0.4 kg

