

1.75"x4", Steel Frame
0.7"PESVW Voice Coil, Kapton Former
Paper Cone, Cloth Surround
Ferrite Magnet Motor System
Low Distortion (<3%)

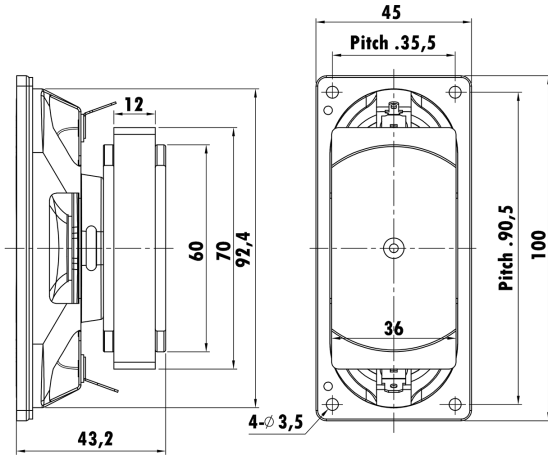

T-S Parameters

Resonance frequency [fs]	180 Hz
Mechanical Q factor [Qms]	3.5
Electrical Q factor [Qes]	1.8
Total Q factor [Qts]	1.2
Force factor [Bl]	2.2 Tm
Mechanical resistance [Rms]	0.7 kg/s
Moving mass [Mms]	2.4 g
Compliance [Cms]	0.3 mm/N
Effective diaph. diameter [D]	33x85.7mm
Effective piston area [Sd]	47.8 cm ²
Equivalent volume [Vas]	1 l
Sensitivity (2.83V/1m)	84 dB
Ratio Bl/√Re	0.8 N/√W
Ratio fs/Qts	150 Hz

Electrical Data

Nominal impedance [Zn]	4 Ω
Minimum impedance [Zmin]	4 Ω
Maximum impedance [Zo]	11.2 Ω
DC resistance [Re]	3.4 Ω
Voice coil inductance [Le]	0.04 mH

Power Handling

100h RMS noise test (IEC 17.1)	36 W
Long-term max power (IEC 17.3)	60 W

Voice Coil & Magnet Data

Voice coil diameter	18.4 mm
Voice coil height	6.5 mm
Voice coil layers	2
Height of gap	3 mm
Linear excursion	± 1.75 mm
Max mech. excursion	± - mm
Unit weight	0.26 kg

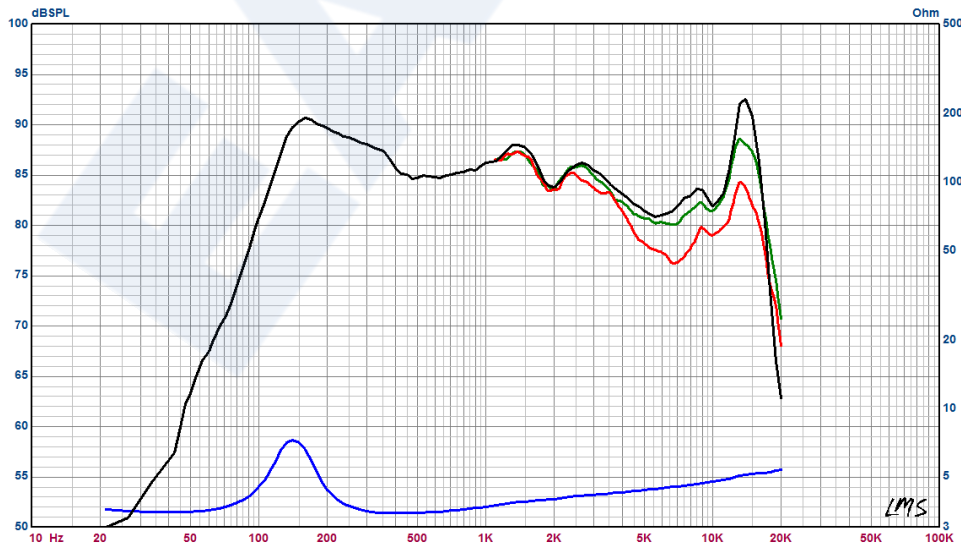

- 60° Off- axis
- 30° Off- axis
- On - axis