

1.75"x4", Steel Frame
0.7"EISVW Voice Coil, Kapton Former
Paper Cone, Cloth Surround
Dual Neodymium Magnet Motor System

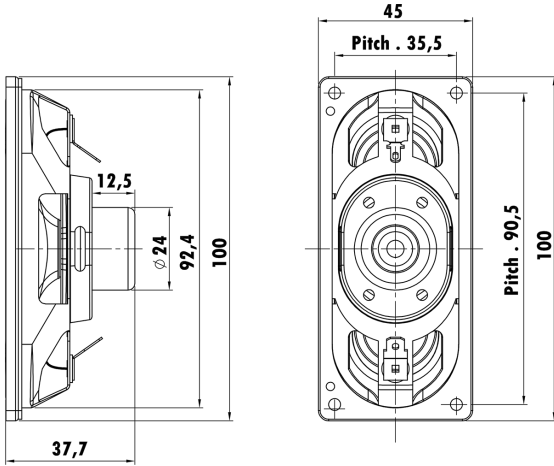

T-S Parameters

Resonance frequency [fs]	203 Hz
Mechanical Q factor [Qms]	3.02
Electrical Q factor [Qes]	2.11
Total Q factor [Qts]	1.24
Force factor [Bl]	2.73 Tm
Mechanical resistance [Rms]	0.92 kg/s
Moving mass [Mms]	2.20 g
Compliance [Cms]	0.28 mm/N
Effective diaph. diameter [D]	33x85.7mm
Effective piston area [Sd]	47.78 cm ²
Equivalent volume [Vas]	0.90 l
Sensitivity (2.83V/1m)	84 dB
Ratio Bl/√Re	1.15 N/√W
Ratio fs/Qts	163.7 Hz

Electrical Data

Nominal impedance [Zn]	6 Ω
Minimum impedance [Zmin]	5.8 Ω
Maximum impedance [Zo]	62.5 Ω
DC resistance [Re]	5.6 Ω
Voice coil inductance [Le]	0.08 mH

Power Handling

100h RMS noise test (IEC 17.1)	10 W
Long-term max power (IEC 17.3)	40 W

Voice Coil & Magnet Data

Voice coil diameter	16.28 mm
Voice coil height	6.6 mm
Voice coil layers	2
Height of gap	3 mm
Linear excursion	± 1.8 mm
Max mech. excursion	± - mm
Unit weight	0.081 kg

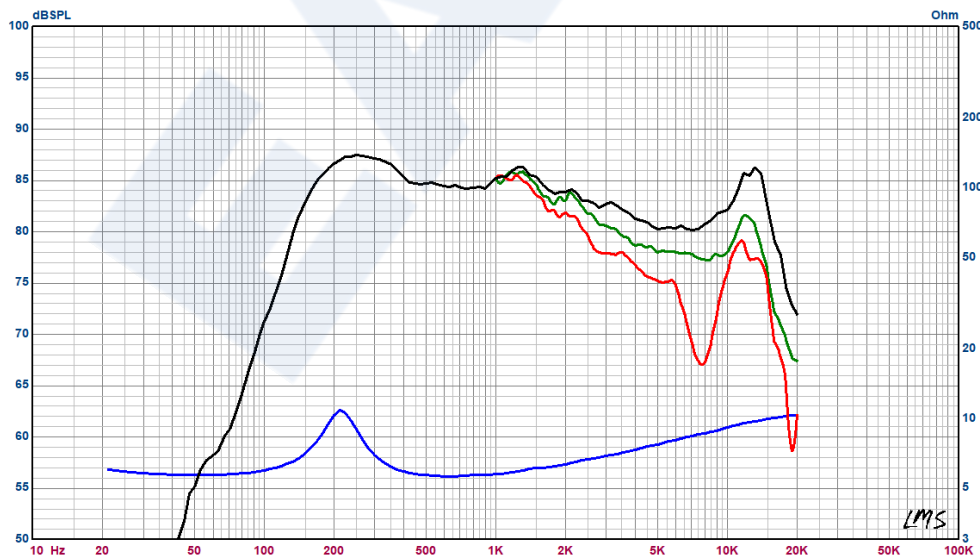

- 60° Off- axis
- 30° Off- axis
- On - axis