

1.75", Steel Frame
0.8" CCAW Voice Coil, Kapton Former
Paper Cone, Rubber Surround
Neodymium Magnet Motor System
Speaker with waterproof

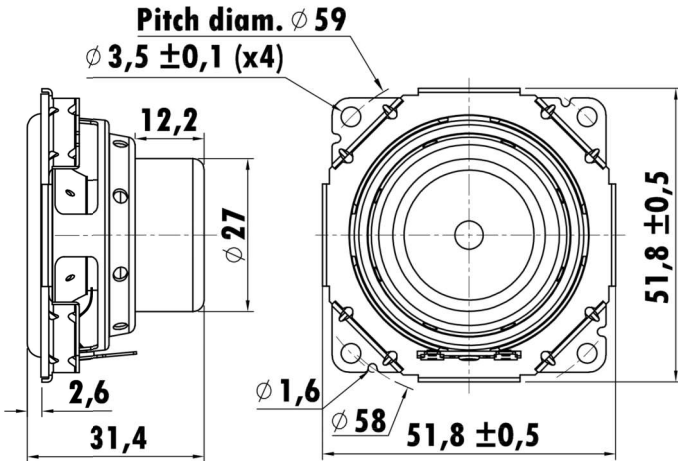

T-S Parameters

Resonance frequency [fs]	163.3 Hz
Mechanical Q factor [Qms]	4.85
Electrical Q factor [Qes]	0.488
Total Q factor [Qts]	0.444
Force factor [Bl]	3.483 Tm
Mechanical resistance [Rms]	0.317 kg/s
Moving mass [Mms]	1.5 g
Compliance [Cms]	0.633 mm/N
Effective diaph. diameter [D]	37 mm
Effective piston area [Sd]	10.75 cm ²
Equivalent volume [Vas]	0.1036 l
Sensitivity (2.83V/1m)	83 dB
Ratio Bl/√Re	1.777 N/√W
Ratio fs/Qts	367.792 Hz

Electrical Data

Nominal impedance [Zn]	4 Ω
Minimum impedance [Zmin]	3.98 Ω
Maximum impedance [Zo]	26.53 Ω
DC resistance [Re]	3.85 Ω
Voice coil inductance [Le]	0.098 mH

Power Handling

100h RMS noise test (IEC 18.4)	10 W
Long-term max power (IEC 18.2)	W

Voice Coil & Magnet Data

Voice coil diameter	19.4 mm
Voice coil height	7.8 mm
Voice coil layers	2
Height of gap	3 mm
Linear excursion	± 2.4 mm
Max mech. excursion	± mm
Unit weight	0.0745 kg

