

1.5", ABS Frame
0.8" PESVCCA W Voice Coil, Aluminum Former
Aluminum Cone, Rubber Surround
Neodymium Magnet Motor System
Low Distortion (<3%)

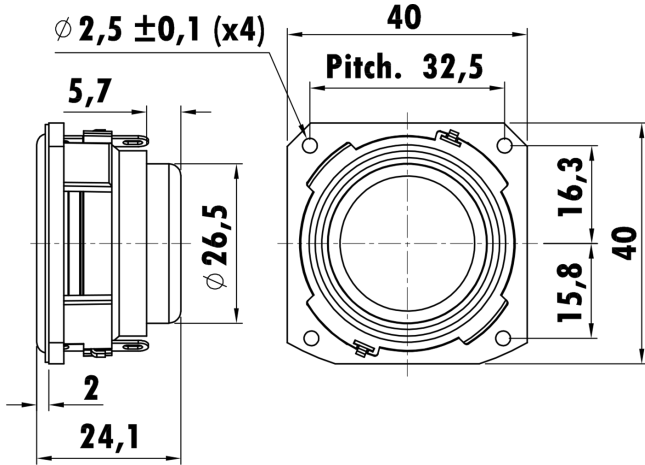

Prototype

T-S Parameters

Resonance frequency [fs]	196.3 Hz
Mechanical Q factor [Qms]	2.910
Electrical Q factor [Qes]	0.745
Total Q factor [Qts]	0.593
Force factor [Bl]	2.58 Tm
Mechanical resistance [Rms]	0.496 kg/s
Moving mass [Mms]	1.169 g
Compliance [Cms]	0.562 mm/N
Effective diaph. diameter [D]	34 mm
Effective piston area [Sd]	9.08 cm ²
Equivalent volume [Vas]	0.0656 l
Sensitivity (2.83V/1m)	82 dB
Ratio Bl/√Re	1.39 N/√W
Ratio fs/Qts	331.02 Hz

Electrical Data

Nominal impedance [Zn]	4 Ω
Minimum impedance [Zmin]	3.44 Ω
Maximum impedance [Zo]	12 Ω
DC resistance [Re]	3.3 Ω
Voice coil inductance [Le]	0.07 mH

Power Handling

100h RMS noise test (IEC 18.4)	5 W
Long-term max power (IEC 18.2)	- W

Voice Coil & Magnet Data

Voice coil diameter	19.4 mm
Voice coil height	4.9 mm
Voice coil layers	2
Height of gap	3 mm
Linear excursion	± 0.95 mm
Max mech. excursion	± - mm
Unit weight	0.052 kg

